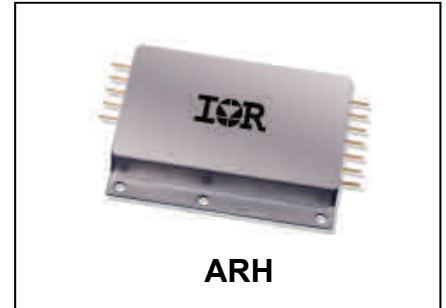

**HYBRID-HIGH RELIABILITY
RADIATION TOLERANT
DC-DC CONVERTER****28V Input, Single Output****Description**

The ARH Series of DC-DC converters has been designed specifically for use in the hostile environments. The high level of radiation tolerance inherent in the ARH design is the result of extensive research, thorough analysis and testing and of careful component specification. Designed to supplement the triple output configuration provided by the ART Series, the ARH circuit topology is the follow-on to the successful ART design and incorporates many of the design features characterizing that product line. Capable of uniform high performance over long term exposures in radiation intense environments, this series expands the standard for distributed power systems demanding high performance and reliability in the harsh environments.

The ARH converters are hermetically sealed in a rugged, low profile package utilizing copper core input and output pins to minimize resistive DC losses. Long-term hermetically is assured through use of parallel seam welded lid attachment along with rugged ceramic pin-to-package seal. Axial orientation of the leads facilitates preferred bulkhead mounting placing the converter on the principal heat-dissipating surface.

Manufactured in a facility fully qualified to MIL-PRF-38534, these converters are fabricated utilizing DLA Land and Maritime qualified processes. For available screening options, refer to device screening table in the data sheet.

Variations in electrical, mechanical and screening specifications can be accommodated. Contact IR HiRel San Jose for special requirements.

Features

- Total Dose > 100 kRads(Si), 2:1 Margin
- SEE Hardened to LET up to 83 MeV.cm²/mg
- De-rated per MIL-STD-975 & MIL-STD-1547
- Output Power to 30 Watts
- Regulates to No-Load
- 18 to 50 Volt Input Range
- Input Under voltage Lockout
- Fully Characterized from -55°C to +125°C
- Continuous Short Circuit Protection
- 12.8 W/in³ Output Power Density
- True Hermetic Package
- External Inhibit Port
- Externally Synchronization
- Fault Tolerant Design
- Available with Outputs from 2.5V to 15V
- Overload Protection
- Standard Microcircuit Drawings Available

Specifications

Absolute Maximum Ratings Note 1		Recommended Operating Conditions Note 2	
Input voltage range	-0.5V _{DC} to +80V _{DC}	Input voltage range	+18V _{DC} to +60V _{DC} +18V to +50V for full de-rating to MIL-STD-1547
Soldering temperature	300°C for 10 seconds	Output power	0 to 30W
Storage case temperature	-65°C to +135°C	Operating case temperature	-55°C to +125°C
			-55°C to +85°C for full de-rating to MIL-STD-975

Static Characteristics -55°C ≤ T_{CASE} ≤ +125°C, V_{IN} = 28V_{DC} ± 5%, C_L = 0, unless otherwise specified.

Parameter	Symbol	Test Conditions	Limits		Unit
			Min.	Max.	
Output voltage ARH2802R5S ARH2803R3S ARH2805S ARH2805R2S ARH2812S ARH2815S	V _{OUT}	P _{OUT} = 30W, T _C = +25°C	2.487 3.283 4.975 5.174 11.940 14.925	2.513 3.317 5.025 5.226 12.060 15.075	V _{DC}
Output power	P _{OUT}	18V _{DC} < V _{IN} < 50V _{DC}	0	30	W
Output current ARH2802R5S ARH2803R3S ARH2805S ARH2805R2S ARH2812S ARH2815S	I _{OUT}	18V _{DC} < V _{IN} < 50V _{DC}	0 0 0 0 0 0	12000 9090 6000 5770 2500 2000	mA _{DC}
Line regulation	Note 3 VR _{LINE}	18 V _{DC} < V _{IN} < 50V _{DC} , 0 < I _{OUT} < I _{MAX}	-1.0	+1.0	%
Load regulation	Note 4 VR _{LOAD}	18 V _{DC} < V _{IN} < 50V _{DC} , 0 < I _{OUT} < I _{MAX}	-2.0	+2.0	%
Total regulation	VR	All conditions of Line, Load, Temperature, Radiation and End of Life	-4.0	+4.0	%
No-load input current	I _{IN}	I _{OUT} = 0 (Pin 3 open) inhibited (Pin 3 shorted to pin 2)	— —	100 8.0	mA
Output ripple and noise voltage Note 5 ARH2802R5S ARH2803R3S ARH2805S ARH2805R2S ARH2812S ARH2815S	V _{RIP}	18 V _{DC} < V _{IN} < 50V _{DC} , I _{OUT} = I _{MAX}		30 30 40 40 50 50	mV _{p,p}
Input ripple current	Note 5 I _{RP}	18 V _{DC} < V _{IN} < 50V _{DC} , I _{OUT} = I _{MAX}		100	mApp
Switching frequency	F _S	Synchronization input open. (pin 6)	225	275	kHz

For Notes to Electrical Performance Characteristics, refer to page 4

Static Characteristics (Continued) $-55^{\circ}\text{C} \leq T_{\text{CASE}} \leq +125^{\circ}\text{C}$, $V_{\text{IN}} = 28\text{V}_{\text{DC}} \pm 5\%$, $C_{\text{L}} = 0$, unless otherwise specified.

Parameter	Symbol	Test Conditions	Limits		Unit
			Min.	Max.	
Efficiency ARH2802R5S ARH2803R3S ARH2805S ARH2805R2S ARH2812S ARH2815S	E_{FF}	$I_{\text{OUT}} = I_{\text{MAX}}$, $T_{\text{C}} = +25^{\circ}\text{C}$	72 75 76 76 80 80		%
Enable input open circuit voltage drive current (sink) voltage range			3.0 -0.5	5.0 100 50	V μA V
Synchronization input frequency range pulse high level pulse low level pulse rise time pulse duty cycle		External clock signal on Sync. input (pin 4)	225 3.5 -0.5 40 20	310 10 0.25 80	kHz V V V/ μs %
Synchronization output pulse high level		Signal compatible with Synchronization Input	3.7	4.3	V
Power dissipation, short circuit ARH2802R5S ARH2803R3S & ARH2805S All Others	P_{D}	Short circuit on output		10 12 9.5	W
Output response to step load changes Note 8 ARH2802R5S ARH2803R3S ARH2805S ARH2805R2S ARH2812S ARH2815S	V_{TLD}	50% Load \leftrightarrow 100% load	-200 -200 -200 -200 -300 -350	200 200 200 200	mV _{PK}
Recovery time from step load changes Notes 8, 9 ARH2802R5S ARH2803R3S ARH2805S ARH2805R2S ARH2812S ARH2815S	T_{TLD}	50% Load \leftrightarrow 100% load		200 200 200 200 200 200	μs
Output response to step line changes Notes 7, 10 ARH2802R5S ARH2803R3S ARH2805S ARH2805R2S ARH2812S ARH2815S	V_{TLN}	$I_{\text{OUT}} = I_{\text{MAX}}$, $V_{\text{IN}} = 18\text{V}$ to/from 50 V	-180 -180 -250 -250 -450 -900	180 180 250 250 450 900	mV _{PK}

For Notes to Electrical Performance Characteristics, refer to page 4

Static Characteristics (Continued) $-55^{\circ}\text{C} \leq T_{\text{CASE}} \leq +125^{\circ}\text{C}$, $V_{\text{IN}} = 28\text{V}_{\text{DC}} \pm 5\%$, $C_{\text{L}} = 0$, unless otherwise specified.

Parameter	Symbol	Test Conditions	Limits		Unit
			Min.	Max.	
Recovery time from step line changes Notes 7, 9, 10 ARH2802R5S ARH2803R3S ARH2805S ARH2805R2S ARH2812S ARH2815S	T_{TLN}	$I_{\text{OUT}} = I_{\text{MAX}}$, $V_{\text{IN}} = 18\text{ V to/from } 50\text{ V}$		600 600 700 700 320 400	μs
Turn on overshoot	V_{OS}	$I_{\text{OUT}} = 10\% \text{ or } 100\% \text{ of } I_{\text{MAX}}$		5.0	% V_{OUT}
Turn on delay Note 11	T_{DLY}	$I_{\text{OUT}} = 10\% \text{ or } 100\% \text{ of } I_{\text{MAX}}$	2.0	20	ms
Capacitive load Notes 6, 7 ARH2802R5S ARH2803R3S ARH2805S ARH2805R2S ARH2812S ARH2815S	C_{L}	No effect on DC performance		1200 1200 1000 1000 180 120	μF
Isolation	I_{SO}	500V _{DC} input to output or Any pin to case	100		M Ω
Recovery from a short circuit	V_{R}	Output shorted, then open into max rated load current. $V_{\text{in}} = 28\text{V}$		10	% of rated output voltage
Overload trip current	O_{VLD}	Maximum current at specified output voltage	105	135	% of max output current

Notes to Specifications

1. Operation outside absolute maximum/minimum limits may cause permanent damage to the device. Extended operation at the limits may permanently degrade performance and affect reliability.
2. Device performance specified in Electrical Performance table is guaranteed when operated within recommended limits. Operation outside recommended limits is not specified.
3. Parameter measured from 28V to 18V or to 50V while load remains fixed at 10%, 50% and 100% of I_{MAX} .
4. Parameter measured from 50% to 10% or 100% of maximum load conditions while line remains fixed at 18, 28 or 50 volts.
5. Guaranteed for a bandwidth of DC to 20 MHz. Tested using a 20 KHz to 2.0 MHz bandwidth.
6. A capacitive load of any value from 0 to the specified maximum is permitted without compromise to DC performance. A capacitive load in excess of the maximum limit may interfere with the proper operation of the converter's short circuit protection, causing erratic behavior during turn on.
7. Parameter is tested as part of design characterization or after design or process changes. Thereafter, parameters shall be guaranteed to the limits specified in the table.
8. Load transient rate of change, $di/dt \leq 2.0\text{ A}/\mu\text{s}$.
9. Recovery time is measured from the initiation of the transient to where V_{OUT} has returned to within $\pm 1\%$ of its steady state value.
10. Line transient rate of change, $dv/dt \leq 50\text{ V}/\mu\text{s}$.
11. Turn on delay time is for either a step application of input power or a logical low to high transition on the enable pin (pin 3) while power is present at the input.

Group A Tests $V_{IN} = 28V$, $C_L = 0$ unless otherwise specified.

Parameter	Symbol	Test Conditions	Group A Subgroups	Limits		Unit
				Min.	Max.	
Output voltage accuracy ARH2802R5S ARH2803R3S ARH2805S ARH2805R2S ARH2812S ARH2815S	V_{OUT}	$I_{OUT} = I_{MAX}$, $T_C = 25^\circ C$	1	2.487 3.283 4.975 5.174 11.940 14.925	2.513 3.317 5.025 5.226 12.060 15.075	V
Output power Note 1	P_{OUT}	$V_{IN} = 18 V, 28V, 50 V$	1, 2, 3	0	30	W
Output current Note 1 ARH2802R5S ARH2803R3S ARH2805S ARH2805R2S ARH2812S ARH2815S	I_{OUT}	$V_{IN} = 18 V, 28V, 50 V$	1, 2, 3	0 0 0 0 0 0	12000 9090 6000 5770 2500 2000	mA
Output regulation Note 4 ARH2802R5S ARH2803R3S ARH2805S ARH2805R2S ARH2812S ARH2815S	V_R	$I_{OUT} = 10\%, 50\%, 100\%$ of I_{MAX} $V_{IN} = 18 V, 28V, 50 V$	1, 2, 3	2.425 3.201 4.850 5.044 11.640 14.550	2.575 3.399 5.150 5.356 12.360 15.450	V
No Load Input Current	I_{IN}	$I_{OUT} = 0$, Pin 3 open Pin 3 shorted to pin 2 (disabled)	1, 2, 3 1, 2, 3		100 8.0	mA
Output ripple Note 2 ARH2802R5S ARH2803R3S ARH2805S ARH2805R2S ARH2812S ARH2815S	V_{RIP}	$V_{IN} = 18 V, 28V, 50 V$ $I_{OUT} = I_{MAX}$	1, 2, 3		30 30 40 40 50 50	mV _{P-P}
Switching frequency	F_S	Synchronization pin (pin 6) open	4, 5, 6	225	275	kHz
Input ripple Note 2	I_{RIP}	$V_{IN} = 18 V, 28V, 50 V$ $I_{OUT} = I_{MAX}$	1, 2, 3		100	mA _{P-P}
Recovery from a short circuit	V_R	Output shorted, then open into max rated load current. $V_{IN} = 28 V$			5.0	% of rated output voltage
Overload trip current	O_{VLD}	Maximum current at specified output voltage	1, 2, 3	105	135	% of max output current

For Notes to Group A Tests, refer to page 6.

Group A Tests (Continued) $V_{IN} = 28V$, $C_L = 0$ unless otherwise specified.

Parameter	Symbol	Test Conditions	Group A Subgroups	Limits		Unit
				Min.	Max.	
Efficiency ARH2802R5S ARH2803R3S ARH2805S ARH2805R2S ARH2812S ARH2815S ARH2802R5S ARH2803R3S ARH2805S ARH2805R2S ARH2812S ARH2815S	E_{FF}	$I_{OUT} = I_{MAX}$	1 2, 3	72 75 76 76 80 80 68 68 72 72 78 78		%
Power dissipation, Short circuit ARH2802R5S ARH2803R3S & ARH2805 All Others	P_D	Short circuit across output	1, 2, 3		10 12 9.5	W
Output response to step load changes Note 5 ARH2802R5S ARH2803R3S ARH2805S ARH2805R2S ARH2812S ARH2815S	V_{TL}	50% Load to/from 100% load	4, 5, 6	-200 -200 -200 -200 -300 -350	200 200 200 200 300 350	mV _{PK}
Recovery from step load changes Notes 5, 6 ARH2802R5S ARH2803R3S ARH2805S ARH2805R2S ARH2812S ARH2815S	T_{TL}	50% Load to/from 100% load	4, 5, 6		200 200 200 200 200 200	μ s
Turn on overshoot	V_{OS}	$I_{OUT} = 10\%$ and 100%	4, 5, 6		5.0	% V_{OUT}
Turn on delay Note 7	T_{DLY}	$I_{OUT} =$ minimum and full rated	4, 5, 6	2.0	20	ms
Isolation	I_{SO}	500V _{DC} Input to output or any pin to case (except pin 12)	1	100		M Ω

Notes to Specifications Tables

- Parameter verified during dynamic load regulation tests.
- Guaranteed for DC to 20 MHz bandwidth. Test conducted using a 20 Hz to 2.0MHz bandwidth.
- Deleted.
- Output is measured for all combinations of line and load. Only the minimum and maximum readings for the output are recorded.
- Load step transition time is 10 μ s.
- Recovery time is measured from the initiation of the transient to where V_{OUT} has returned to within $\pm 1\%$ of its steady state value.
- Turn on delay time is tested by application of a logical low on high transition on the enable pin (pin 3) with power present at the input.
- Subgroups 1 and 4 are performed at +25°C, subgroups 2 and 5 at +85°C and subgroups 3 and 6 at -55°C.

Fig I. Block Diagram

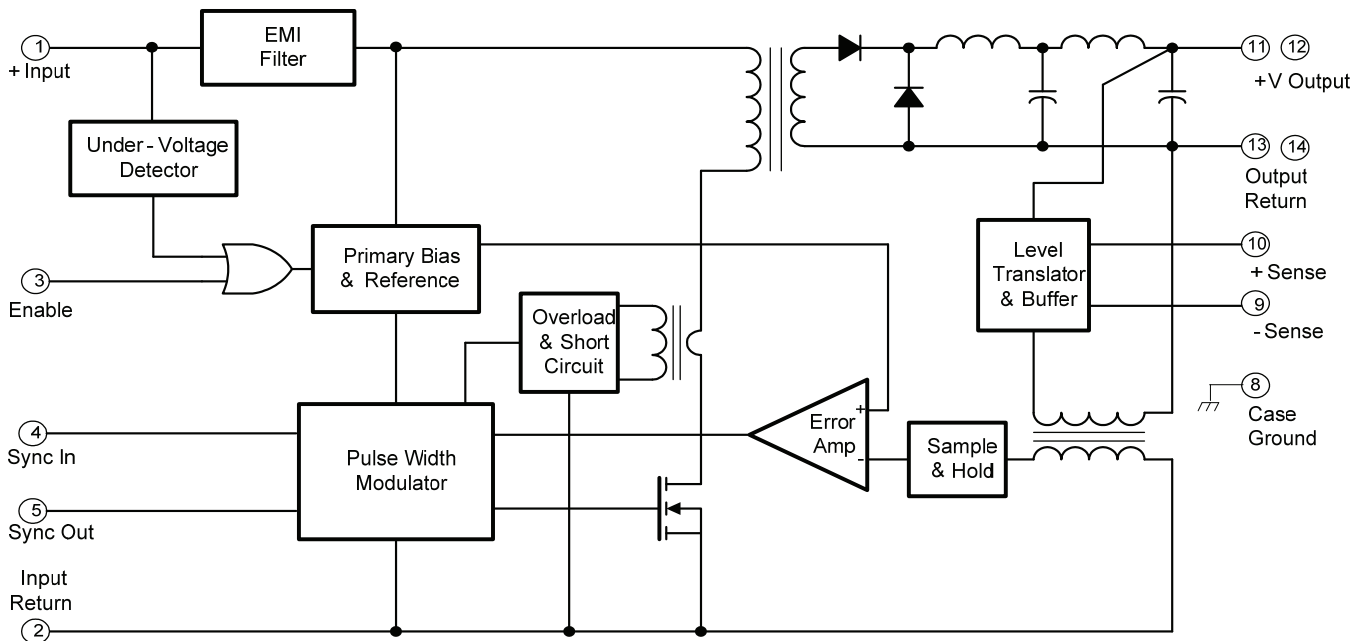

Circuit Operation and Application Information

The ARH28XXXXS Series of converters have been designed using a single ended forward switched mode converter topology. (Refer to Fig I.) Single ended topologies enjoy certain advantages in radiation hardened designs in that they eliminate the possibility of simultaneous turn on of both switching elements during a radiation induced upset. In addition, single ended topologies are not subject to transformer saturation problems often associated with double ended implementations.

The design incorporates a two-stage LC input filter to attenuate input ripple current. A low overhead linear bias regulator provides both a bias voltage for the converter primary control logic and a stable, well-regulated reference for the error amplifier. Output control is realized using a wide band discrete pulse width modulator control circuit incorporating a unique non-linear ramp generator circuit. This circuit helps stabilize loop gain over variations in line voltage for superior output transient response. Nominal conversion frequency has been selected as 250 kHz to maximize efficiency and minimize magnetic element size.

Output voltages are sensed and fed back to the controller using a patented magnetic feedback circuit. This circuit is designed to be relatively insensitive to variations in temperature, aging, radiation and manufacturing tolerances making it particularly well suited to radiation hardened designs. The control logic has been designed to use only radiation tolerant components, and current paths include series resistances to limit photocurrents.

Other key circuit design features include output short circuit and overload protection, input under voltage lockout and an external synchronization input port, permitting operation at an externally set clock rate. Alternately, a synchronization output is provided to lock frequencies with another converter when using more than one converter in a system.

Thermal Considerations

The ARH Series of converters is capable of providing relatively high output power from a package of modest volume. The power density exhibited by these devices is obtained by combining high circuit efficiency with effective methods of heat removal from the die junctions. Good design practices have effectively addressed this requirement inside the device. However when operating at maximum loads, heat generated at the die junctions depends upon minimally restricted thermal conduction from the base plate for that heat to be carried away. To maintain case temperature at or below the specified maximum of 125°C, this heat can be transferred by attachment of the ARH28XXXXS to an appropriate heat dissipater held in intimate contact with the converter base-plate.

Effectiveness of this heat transfer is dependent on the intimacy of the baseplate to heat sink interface. It is therefore suggested that a heat-transferring medium possessing good thermal conductivity be inserted between the baseplate and heat sink. A material utilized at the factory during testing and burn-in processes is sold under the trade name of Sil-Pad® 4001. This particular product is an insulator but electrically conductive versions are also available. Use of these materials assures optimum surface contact with the heat dissipater by compensating for minor surface variations.

While other available types of heat conducting materials and thermal compounds provide similar effectiveness, these alternatives are often less convenient and are sometimes messy to use.

A conservative aid to estimating the total heat sink surface area ($A_{HEAT\ SINK}$) required to set the maximum case temperature rise (ΔT) above ambient temperature is given by the following expression:

$$A_{HEAT\ SINK} \approx \left\{ \frac{\Delta T}{80P^{0.85}} \right\}^{-1.43} - 5.94$$

Where

ΔT = Case temperature rise above ambient

$$P = \text{Device dissipation in Watts} = P_{out} \left\{ \frac{1}{Eff} - 1 \right\}$$

As an example, assume that it is desired to maintain the case temperature of an ARH2815S at +65°C or less while operating in an open area whose ambient temperature does not exceed +35°C; then

$$\Delta T = 65 - 35 = 35^\circ\text{C}.$$

From the Specification Table, the worst case full load efficiency for this device is 80%; therefore the maximum power dissipation at full load is given by

$$P = 30 \bullet \left\{ \frac{1}{.80} - 1 \right\} = 30 \bullet (0.25) = 7.5\text{W}$$

and the required heat sink area is

$$A_{HEAT\ SINK} = \left\{ \frac{35}{80 \bullet 7.5^{0.85}} \right\}^{-1.43} - 5.94 = 31.8\ \text{in}^2$$

Thus, a total heat sink surface area (including fins, if any) of approximately 32 in² in this example, would limit case rise to 35°C above ambient. A flat aluminum plate, 0.25" thick and of approximate dimension 4" by 4" (16 in² per side) would suffice for this application in a still air environment. Note that to meet the criteria, both sides of the plate require unrestricted exposure to the ambient air. The user should remember that when operating in the vacuum of space, this method does not apply and all heat must be conducted away from the attaching surface.

¹Sil-Pad is a registered Trade Mark of Bergquist, Minneapolis, MN

Inhibiting Converter Output

As an alternative to application and removal of the DC voltage at the input, the user can control the converter output by providing an input referenced, TTL compatible, logic signal to the enable pin 3. This port is internally pulled "high" so that when not used, an open connection on the pin permits normal converter operation.

When inhibited outputs are desired, a logical "low" on this port will shut the converter down. An open collector device capable of sinking at least 100 μA connected to enable pin 3 will work well in this application.

A benefit of utilization of the enable input is that following an initial charge of the input capacitor, subsequent turn-on commands will induce no uncontrolled current inrush.

Figure II. Enable Input Equivalent Circuit

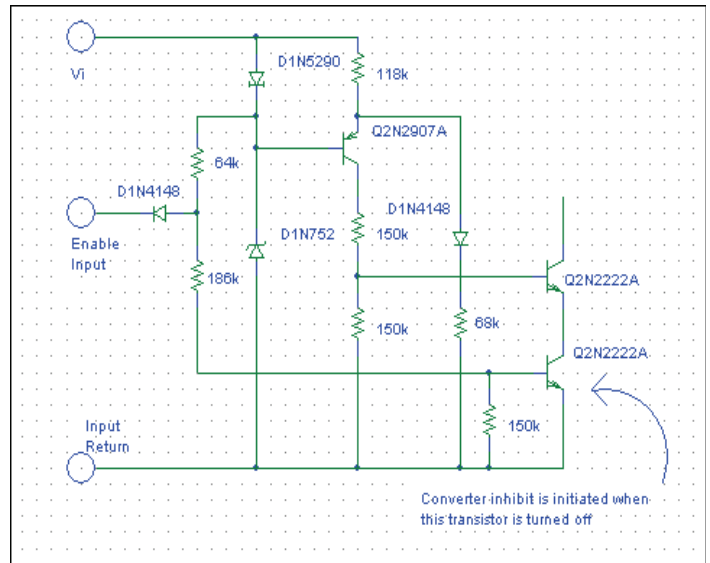

Synchronization

When using multiple converters, system requirements may dictate operating several converters at a common system frequency. To accommodate this requirement, the ARH28XXXXS type converter provides a synchronization input port.

The sync input port permits synchronization of an ARH converter to any compatible external frequency source operating in the band of 225 to 310 kHz. In the event of failure of an external synchronization source, the converter will revert to its own internally set frequency. When external synchronization is not desired, the sync in port may be left open (unconnected) permitting the converter to operate at its own internally set frequency.

When an external frequency source is not available, an internal clock signal is provided through appropriate buffering at the sync out port. This port can drive a minimum of 3 ARH sync in ports thereby allowing all to operate at the same clock frequency.

Output Short Circuit Protection

Protection against accidental short circuits on the output is provided in the ARH28XXXXS converter. This protection is implemented by sensing primary switching current and reducing the switching pulse widths when a short occurs. The output current is therefore limited to a maximum value, which protects the converter. Under this condition the internal power dissipation is nearly the same as for maximum loading.

Input Under voltage Protection

A minimum voltage is required at the input of the converter to initiate operation. This voltage is set to a nominal value of 16.8 volts. To preclude the possibility of noise or other voltage variations at the input falsely initiating and halting converter operation, a hysteresis of approximately 1.0 volts is incorporated into this circuit. The converter is guaranteed to operate at 18 Volts input under all specified conditions.

Input Filter

To attenuate input ripple current, the ARH28XXXXS Series converters incorporate a two-stage LC input filter illustrated in Fig. III following. The elements of this filter comprise the dominant input load impedance characteristic, and therefore determine the nature of the current inrush at turn-on.

Figure III. Input Filter

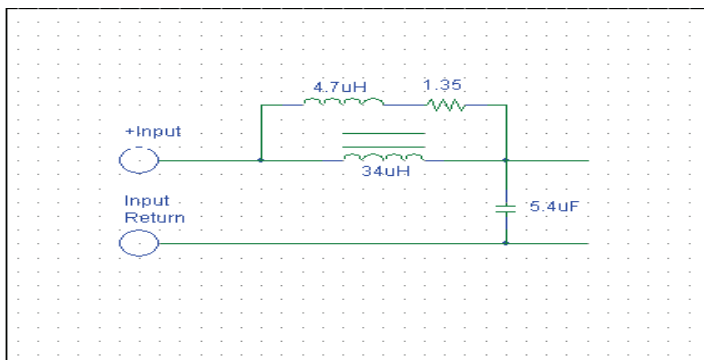

EMI Filtering

Although the internal filtering provided at both input and output terminals of the ARH Series converters is sufficient for most applications, some critical applications may require additional filtering in order to accommodate particular system requirements.

While the internal input filter maintains input ripple current below 50mA_{p-p}, an external filter can be applied to further attenuate this ripple to a level below the CE03 limits imposed by MIL-STD-461. International Rectifier currently supplies such a filter housed in a complementary package. The catalog number of this part is ARF461.

Output Noise

When attempting noise measurement at the output of switching converters, measurement techniques employed can have a significant influence on results during these tests. Any noise measurements should be undertaken only with test leads dressed as close to the device output pins as is physically possible. Probe ground leads should be kept to a minimum (<< 1") length to minimize the influence of parasitic impedances on results.

Radiation Performance

The radiation tolerance characteristics inherent in the ARH28XXXXS converters are a result of a carefully planned ground-up design program with specific radiation design goals. Identification of the general circuit topology, a fundamental task in design effort, was followed by selection of appropriate elements from a list of devices for which extensive radiation effects data was available. By imposing sufficiently large margins on those electrical parameters showing the worst case degrading effects of radiation, designers were able to select appropriate elements for incorporation into the circuit. Existing radiation data was utilized for input to PSPICE and Rad SPICE in the generation of circuit performance verification analyses. Thus, electrical performance capability under all environmental conditions including radiation was well understood before first application of power to the inputs.

A principal design goal was achieving a converter topology that, because of large design margins, had radiation performance essentially independent of radiation induced element-lot performance variations. Where such margins cannot be assured, element lots are either selected following RLAT characterization as radiation hard devices or, purchased as radiation hard devices so that realization of the design goals are maintained.

The following table specifies guaranteed minimum radiation exposure levels tolerated while maintaining specification limits.

Radiation Specification T_{case} = 25°C

Parameter	Condition	Min	Typ	Max	Unit
Total Ionizing Dose (2 :1 Margin)	MIL-STD-883, Method 1019.4 Operating bias applied during exposure	100			kRads (Si)
Dose Rate Temporary Saturation Survival	MIL-STD-883, Method 1021	1E8 1E11			Rads(Si)/sec
Heavy Ion (Single event effects)	BNL Dual Van de Graf Generator	83			MeV·cm ² /mg

IR HiRel currently does not have a DLA certified Radiation Hardness Assurance Program.

Standard Quality Conformance Inspections on ARH28XXXXS Series (Flight Screened)

Inspection	Application	Samples
Group A	Part of screening on each unit	100%
Group B	Each inspection lot	* 5 units
Group C	First inspection lot or following class 1 change	10 units
Group D	In line (Part of element evaluation)	3 units

* Group B quantity for option 2 End of Line QCI. No Group B samples required for Option 1, In-line.

Mechanical Outline

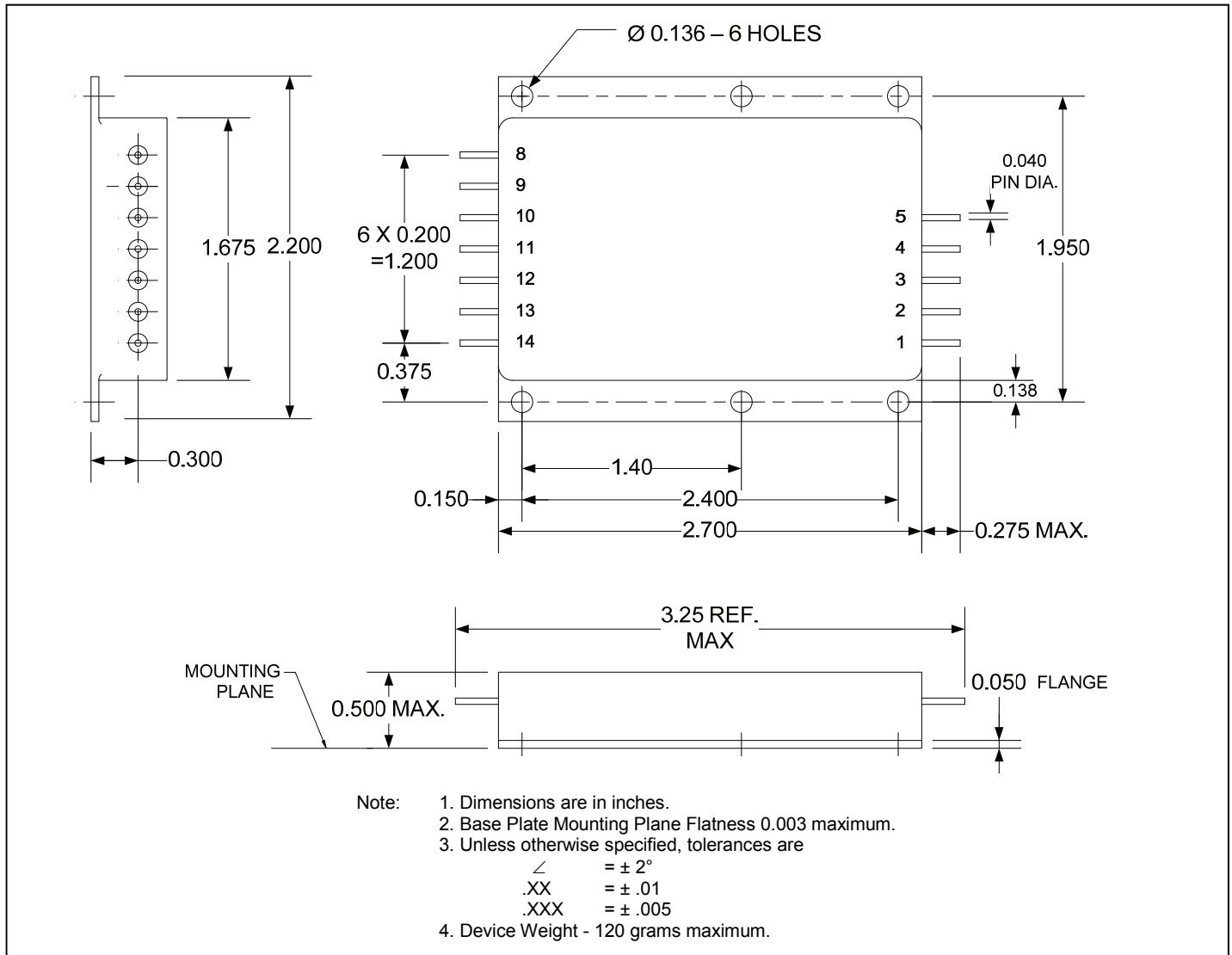

Pin Designation

Pin #	Designation	Pin #	Designation
1	+ Input	8	Case Ground
2	Input Return	9	-Sense
3	Enable	10	+ Sense
4	Sync In	11	+V Output
5	Sync Out	12	+V Output
		13	Output Return
		14	Output Return

Standard Microcircuit Drawing Equivalence Table

Standard Microcircuit Drawing Number	IR HiRel Standard Part Number
5962-04232	ARH2805S
5962-04233	ARH2803R3S

Device Screening

Requirement	MIL-STD-883 Method	No Suffix ②	CK ②	EM ③
Temperature Range	—	-55°C to +85°C	-55°C to +85°C	-55°C to +85°C
Element Evaluation	MIL-PRF-38534	Class K	Class K	N/A
Non-Destructive Bond Pull	2023	Yes	Yes	N/A
Internal Visual	2017	Yes	Yes	①
Temperature Cycle	1010	Cond C	Cond C	Cond C
Constant Acceleration	2001, Y1 Axis	3000 Gs	3000 Gs	3000 Gs
PIND	2020	Cond A	Cond A	N/A
Burn-In	1015	320 hrs @ 125°C (2 x 160 hrs)	320 hrs @ 125°C (2 x 160 hrs)	48 hrs @ 125°C
Final Electrical (Group A)	MIL-PRF-38534 & Specification	-55°C, +25°C, +85°C	-55°C, +25°C, +85°C	-55°C, +25°C, +85°C
PDA	MIL-PRF-38534	2%	2%	N/A
Seal, Fine and Gross	1014	Cond A, C	Cond A, C	Cond A
Radiographic	2012	Yes	Yes	N/A
External Visual	2009	Yes	Yes	①

Notes:

- ① Best commercial practice.
- ② CK is a DLA class K compliant without radiation performance. No suffix is a radiation rated device but not available as a DLA qualified SMD per MIL-PRF-38534.
- ③ Any Engineering Model (EM) build with the “EM” Suffix shall only be form, fit and functional equivalent to its Flight Model (FM) counterpart, and it may not meet the radiation performance. The EM Model shall not be expected comply with MIL-PRF-38534 flight quality/workmanship standards, and configuration control. An EM build may use electrical equivalent commercial grade components. IR HiRel will provide a list of non-compliance items upon request.

Part Numbering

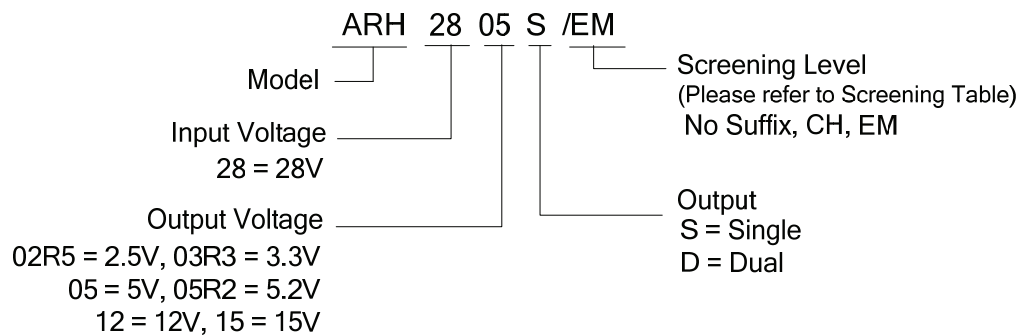

IMPORTANT NOTICE

The information given in this document shall be in no event regarded as guarantee of conditions or characteristic. The data contained herein is a characterization of the component based on internal standards and is intended to demonstrate and provide guidance for typical part performance. It will require further evaluation, qualification and analysis to determine suitability in the application environment to confirm compliance to your system requirements.

With respect to any example hints or any typical values stated herein and/or any information regarding the application of the product, Infineon Technologies hereby disclaims any and all warranties and liabilities of any kind including without limitation warranties on non- infringement of intellectual property rights and any third party.

In addition, any information given in this document is subject to customer's compliance with its obligations stated in this document and any applicable legal requirements, norms and standards concerning customer's product and any use of the product of Infineon Technologies in customer's applications.

The data contained in this document is exclusively intended for technically trained staff. It is the responsibility of any customer's technical departments to evaluate the suitability of the product for the intended applications and the completeness of the product information given in this document with respect to applications.

For further information on the product, technology, delivery terms and conditions and prices, please contact your local sales representative or go to (www.infineon.com/hirel).

WARNING

Due to technical requirements products may contain dangerous substances. For information on the types in question, please contact your nearest Infineon Technologies office.